



Cambridge International Examinations
Cambridge International General Certificate of Secondary Education

CANDIDATE
NAME

CENTRE
NUMBER

--	--	--	--	--

CANDIDATE
NUMBER

--	--	--	--



DESIGN AND TECHNOLOGY

0445/33

Paper 3 Resistant Materials

May/June 2015

1 hour

Candidates answer on the Question Paper.

No Additional Materials are required.

READ THESE INSTRUCTIONS FIRST

Write your Centre number, candidate number and name on all the work you hand in.

Write in dark blue or black pen.

You may use an HB pencil for any diagrams, graphs or rough working.

Do not use staples, paper clips, glue or correction fluid.

DO NOT WRITE IN ANY BARCODES.

Section A

Answer **all** questions in this section.

Section B

Answer **one** question in this section.

You may use a calculator.

At the end of the examination, fasten all your work securely together.

The number of marks is given in brackets [] at the end of each question or part question.

The total of the marks for this paper is 50.

This document consists of **16** printed pages.

Section A

Answer **all** questions in this section.

1 Fig. 1 shows a student using a drilling machine safely.



Fig. 1

State **three** safety precautions taken by the student using the drilling machine.

- 1
- 2
- 3 [3]

2 Many items of furniture are made from chipboard.
State **two** advantages of making furniture from chipboard rather than from solid wood.

- 1
- 2 [2]

3 Complete the table below by naming a suitable adhesive for each of the described uses.

Use	Adhesive
gluing plastic laminate to a manufactured board table top	
wooden boat building	
gluing metal parts together	

[3]

4 Name a suitable finish for the following products.

aluminium comb

wooden chopping board

handle of a junior hacksaw[3]

5 Fig. 2 shows a toy car and a machine part. Both are made by the die casting process.

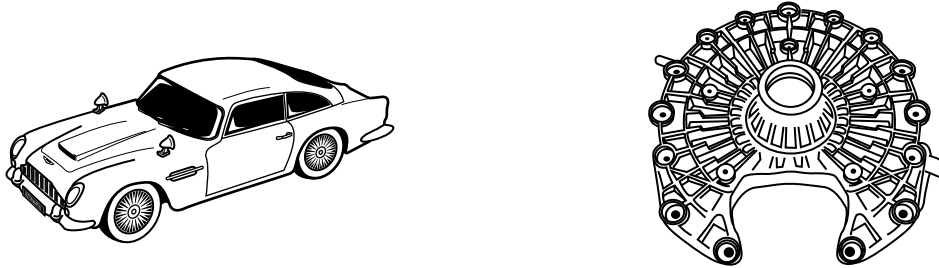

Fig. 2

Give **two** benefits of using the die casting process to make products.

1

2[2]

6 Name the process that uses the equipment shown in Fig. 3.

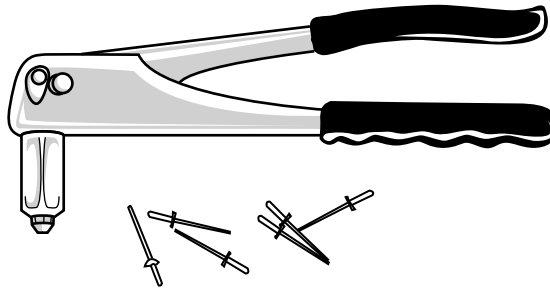

Fig. 3

.....[1]

7 Fig. 4 shows two pieces of wood nailed together.

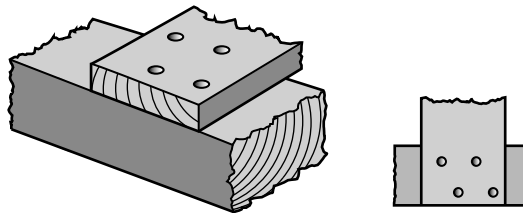

Fig. 4

(a) Give **one** reason why the nails are arranged as shown in Fig. 4.

.....[1]

(b) Give the specific name of **one** type of nail that could be used to join wood together.

.....[1]

(c) Name a tool that could be used to pull nails out of wood.

.....[1]

8 Complete the drawing below to show the marking out for a mortise and tenon joint.

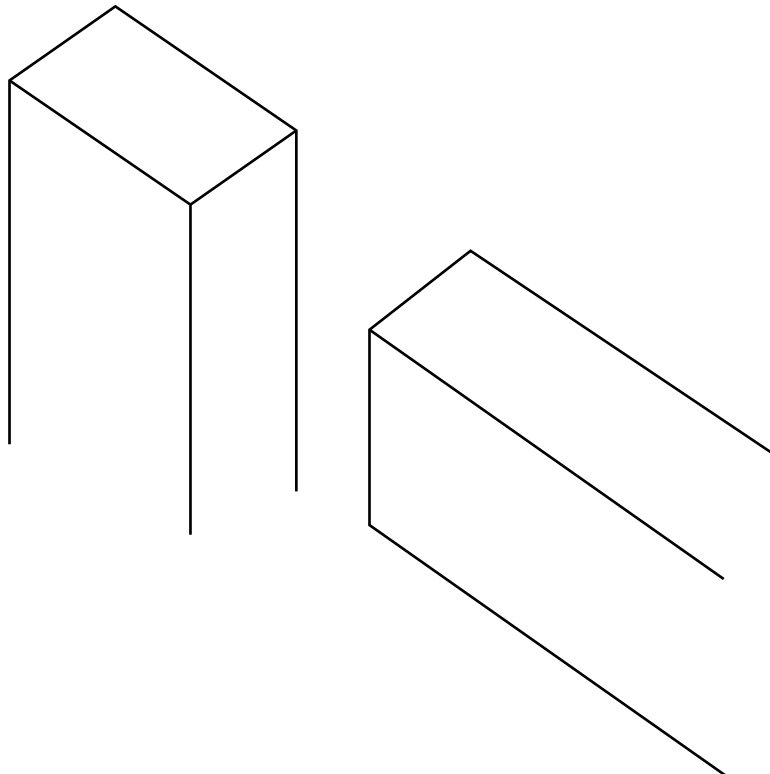

[3]

9 Fig. 5 shows two centre lathe operations.

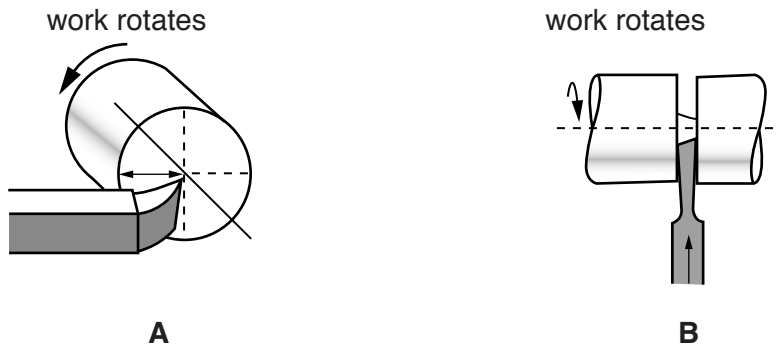

Fig. 5

Select the correct centre lathe operation for **A** and **B** from the list below.

cutting off parting off shearing off facing off turning off

Operation **A**

Operation **B** [2]

10 Complete the table below by naming a specific plastic for each product.

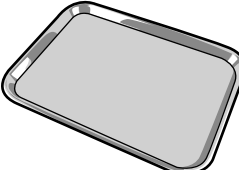
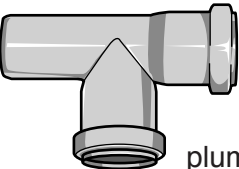
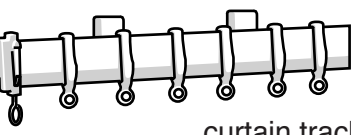
Product	Specific plastic
 <p>food tray</p>	
 <p>plumbing pipe</p>	
 <p>curtain track</p>	

[3]

Section B

Answer **one** question in this section.

- 11 Fig. 6 shows detailed views of a photograph holder made from 4 mm thick clear acrylic.

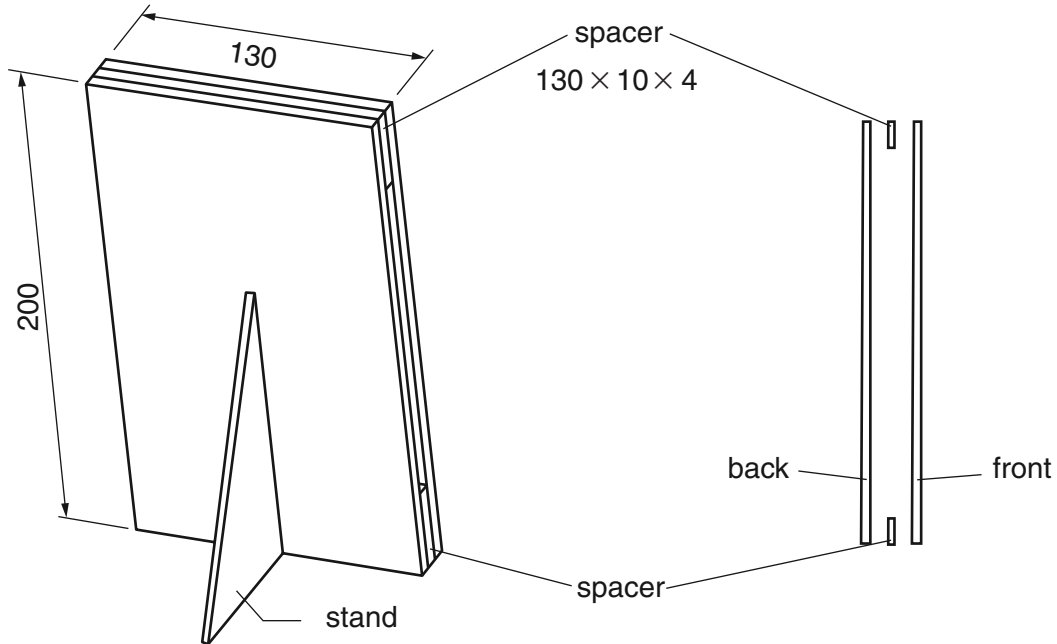

Fig. 6

- (a) Fig. 7 shows the stand for the photograph holder marked out ready to be cut to shape.

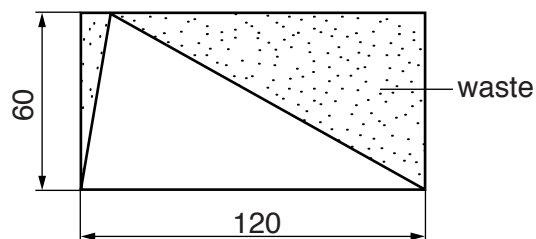

Fig. 7

Complete the table below by describing what each tool or item of equipment is used for.

Stage	Tool / item of equipment	Use
1	scriber	
2	hegner or scroll saw	
3	hand file	
4	wet and dry paper	

[4]

- (b) The front and back are joined to the spacers with acrylic cement.
Give **two** safety precautions that must be taken when using acrylic cement.

1

2 [2]

- (c) Fig. 8 shows views of a photograph holder made from 1 mm thick aluminium sheet.

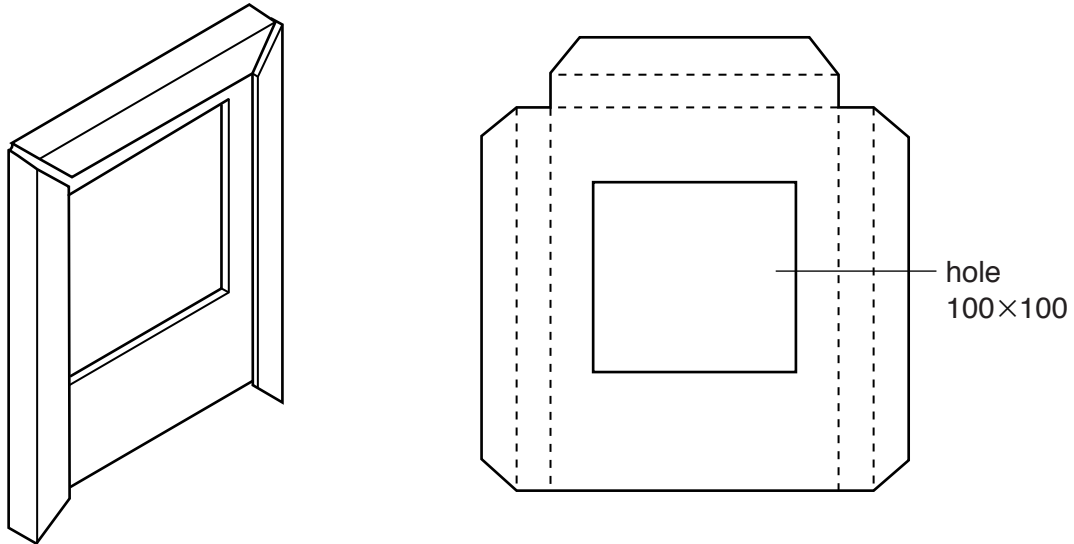

Fig. 8

Give **two** properties of aluminium that make it suitable for the photograph holder.

1

2 [2]

- (d) Use sketches and notes to show how you would cut out the square hole in the 1 mm thick aluminium sheet shown in Fig. 8.

[5]

(e) Describe how the aluminium sheet would be finished to a high quality.

.....
.....
.....
.....[3]

(f) A batch of twenty identical aluminium photograph holders will be made in a school workshop. Use sketches and notes to show how the sides of the aluminium photograph holder, shown in Fig. 8, could be folded accurately.

[5]

(g) There are benefits of using CAD (Computer Aided Design) and CAM (Computer Aided Manufacture) when designing and making the photograph holders in Fig. 6 and Fig. 8.

(i) Explain **one** benefit of using CAD to design the photograph holders.

.....
.....
.....[2]

(ii) Explain **one** benefit of using CAM to make the photograph holders.

.....
.....
.....[2]

12 Fig. 9 shows views of a planter in which flowers can be grown.
 The planter is made from 15 mm thick solid wood and is sold as flat-pack for self-assembly.

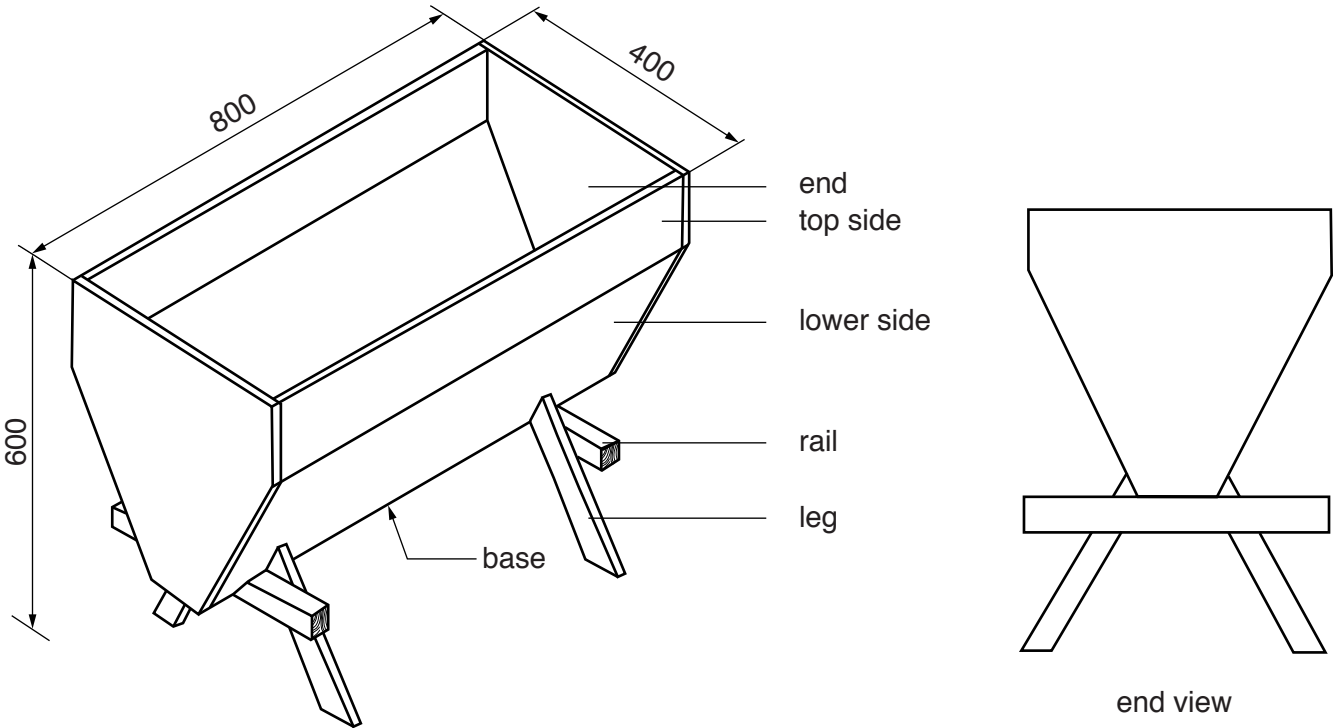

Fig. 9

- (a) Describe **one** property of solid wood that makes it suitable for use in a planter.
[1]
- (b) Name **two** solid woods that would be suitable for the planter.
 1
 2[2]
- (c) Name **two** finishes that would be suitable for the planter.
 1
 2[2]

- (d) Use sketches and notes to show a modification to the planter that would make it easier to carry. Include details of materials and/or methods of construction.

[4]

(e) Customers must be able to assemble the planter using only:

- wood screws;
- nuts and bolts;
- dowels and adhesive.

(i) Use sketches and notes to show how these **three** methods of construction could be used to join different parts of the planter.

[12]

(ii) List **four** stages in the order customers should assemble the various parts of the planter.

- 1
- 2
- 3
- 4 [4]

13 Fig. 10 shows a magazine rack made from acrylic.

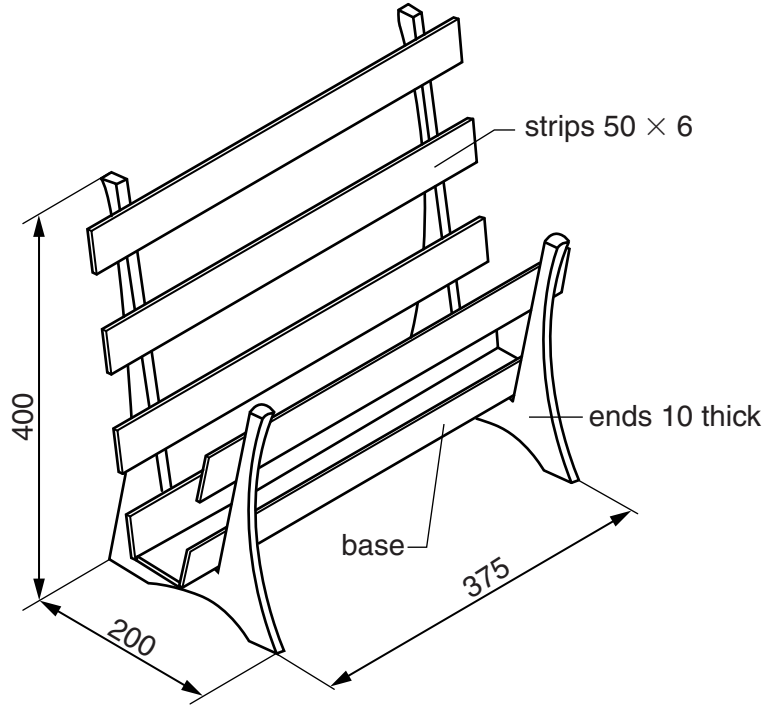

Fig. 10

(a) Identify **three** areas of research that would need to be carried out when designing the magazine rack.

- 1
- 2
- 3 [3]

(b) Fig. 11 shows a template of the shape of one end of the magazine rack glued on to acrylic sheet.

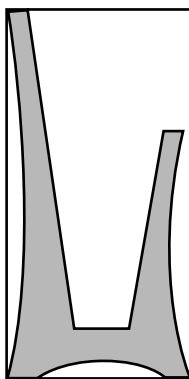

Fig. 11

Give **two** benefits of using a template when marking out.

- 1
- 2 [2]

(c) Fig. 12 shows views of the base of the magazine rack.

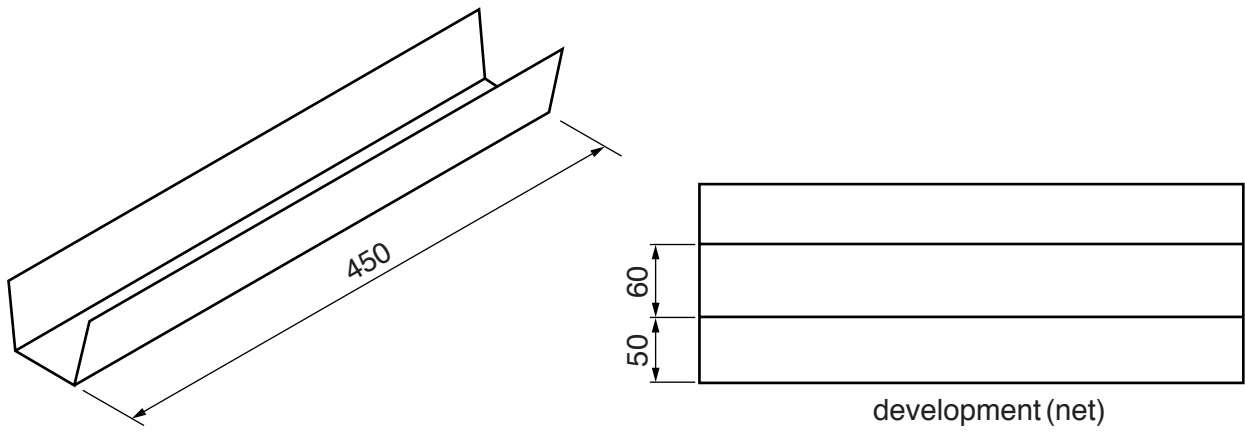

Fig. 12

(i) Use sketches and notes to show how the development (net) of the tray would be heated and bent to shape.

[3]

(ii) Explain why it would be an advantage to use a strip heater or line bender, rather than an oven, to heat the acrylic.

.....
.....
.....[2]

(d) The strips will be cut from a length of acrylic.
Each of the strips will be fixed to the ends using acrylic cement.

(i) Describe how you would make sure that **all** the strips were cut and finished to the same length.

.....
.....
.....[2]

(ii) Use sketches and notes to show how the strips could be equally spaced and held in position while the acrylic cement sets.

[4]

Question 13(e) is printed on the next page.

- (e) (i) Many magazine racks are made from wood. Use sketches and notes to show how the magazine rack shown in Fig. 10 could be redesigned using wood. Include the specific names of the wood used and methods of construction.

[6]

- (ii) Explain why wooden magazine racks could be considered to be more environmentally friendly than those made from plastic materials.

.....

.....

.....

..... [3]

Permission to reproduce items where third-party owned material protected by copyright is included has been sought and cleared where possible. Every reasonable effort has been made by the publisher (UCLES) to trace copyright holders, but if any items requiring clearance have unwittingly been included, the publisher will be pleased to make amends at the earliest possible opportunity.

To avoid the issue of disclosure of answer-related information to candidates, all copyright acknowledgements are reproduced online in the Cambridge International Examinations Copyright Acknowledgements Booklet. This is produced for each series of examinations and is freely available to download at www.cie.org.uk after the live examination series.

Cambridge International Examinations is part of the Cambridge Assessment Group. Cambridge Assessment is the brand name of University of Cambridge Local Examinations Syndicate (UCLES), which is itself a department of the University of Cambridge.